

PERFORMANCE CURVES

BOL Models with Standard P-BAR Core

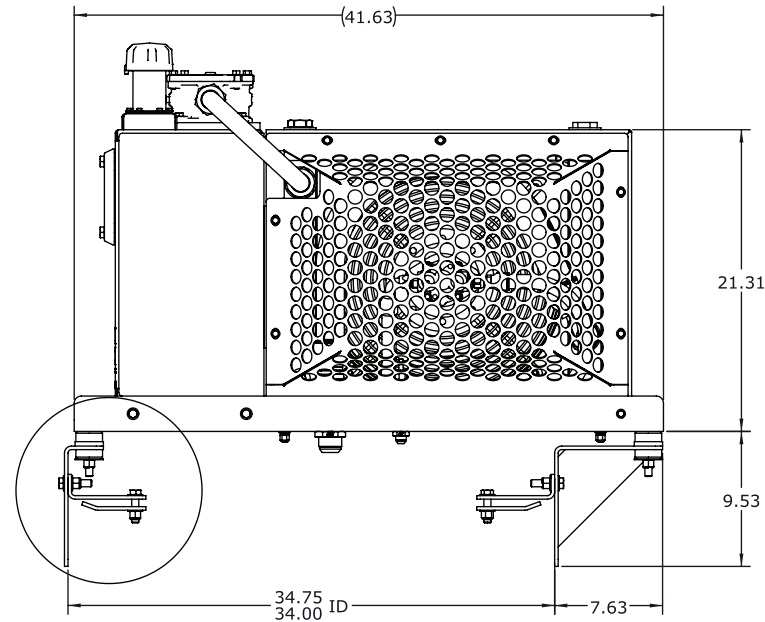
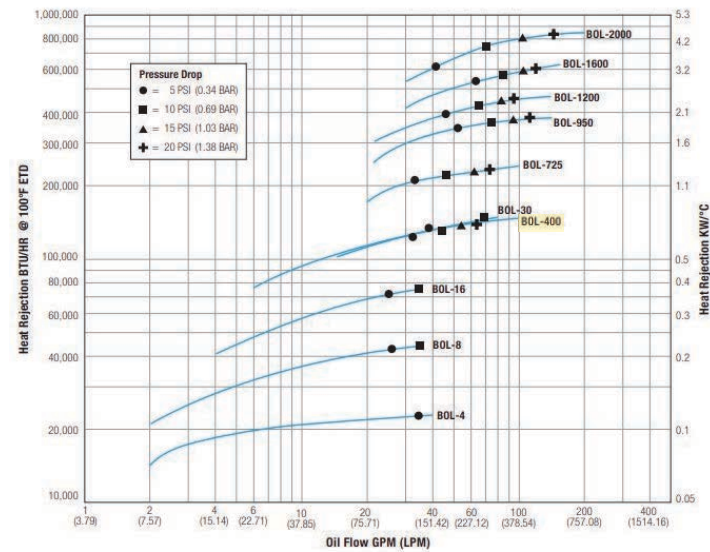

PACKAGE DIMENSIONS

Each UK9-70-HYD-SS-60B comes standard with a 10 micron filler breather, 10 micron filter with a 60 psi bypass, and quick mount bracket set.

Port Sizes

- Suction 2" NPT
- Relief Valve Return 1" NPT
- Drain 3/4" NPT
- Cooler Return SAE - 20

Weight

Dry Weight 350 lbs

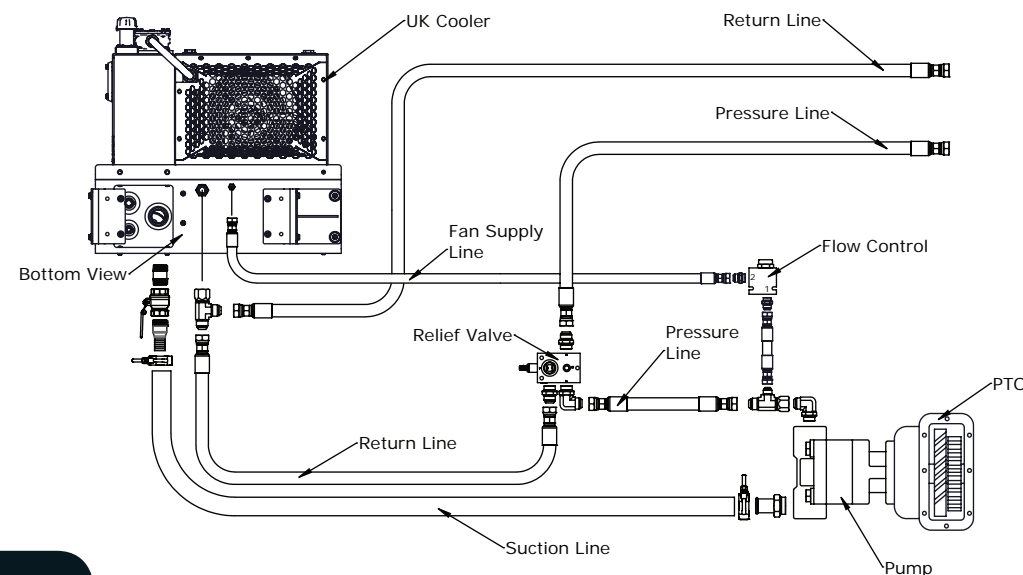

FEATURES

The Ultra-Kool is a compact hydraulic reservoir, filter and cooler system. The stainless steel construction, EnduraGuard™ filter housing and filler breather, and frame isolation mounts make this perfect for severe applications.

High Flow Capacity

- 70 GPM rated flow
- SAE -20 return ports for low pressure drop
- Nine gallon reservoir capacity

Multiple Mounting Options

- System includes quick mount brackets, no drilling required
- Option to mount direct to truck frame

High Performance Cooler

- Up to 135,000 BTU/HR or 53 HP of heat rejection
- Integrated 60 PSI cold oil bypass

Space Saving Design

- Behind the cab mounting requires less than 16" of space

Hydraulic Driven Fan

- 08 JIC bulkhead for hydraulic fan connection
- Flow controls can be driven right off the pressure side of the PTO or clutch pump



1-888-99-FORCE

501 East Cliff Road Burnsville, Minnesota 55337 www.forceamerica.com

Bismarck, ND 800-624-7568	Denver, CO 888-833-7711	Minneapolis, MN 800-328-2732
Charlotte, NC 800-788-8598	Fort Dodge, IA 800-362-2994	Philadelphia, PA 800-492-6621
Chicago, IL 800-433-5765	Kansas City, MO 800-383-4724	Salt Lake City, UT 877-230-0505
Columbus, OH 888-449-0356	Memphis, TN 888-845-5876	
Dallas, TX 800-893-7225	Milwaukee, WI 800-722-5844	

Atlanta, GA (Atlanta Powertrain™) 888-293-2325	www.atlantapowertrain.com
Seattle, WA (Mobile Equipment Systems™) 800-354-9028	www.mobileequip.com

Service Centers and Sales

MOUNTING OPTIONS

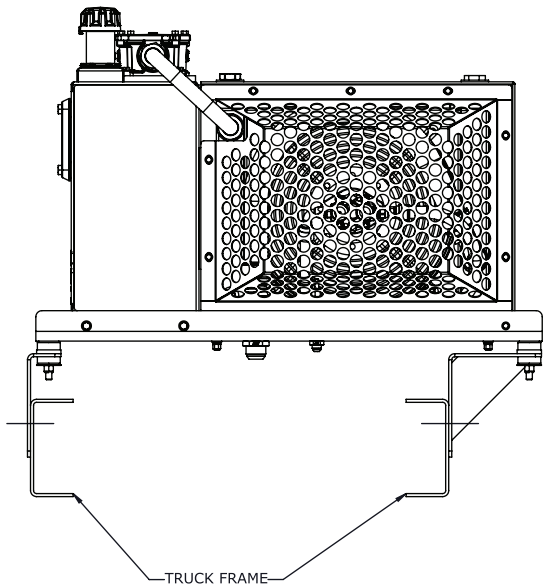

DIRECT MOUNT
Directly mount the provided brackets to the truck frame and discard the quick mount brackets.

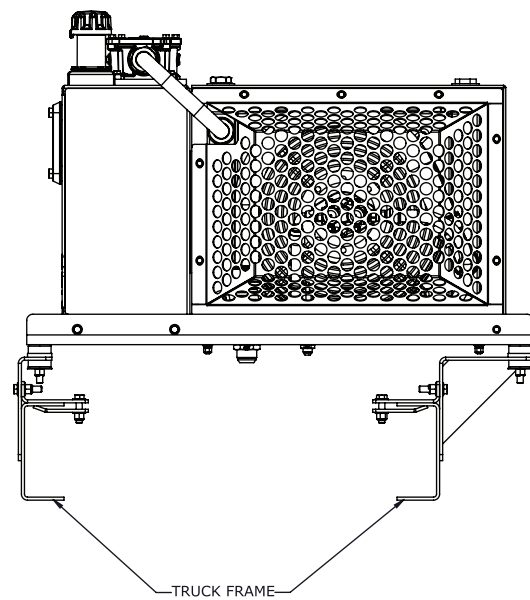

QUICK MOUNT OPTION #1
Use quick mount brackets to attach to the top of the truck frame rail. Does not require any drilling or modification to the truck frame.

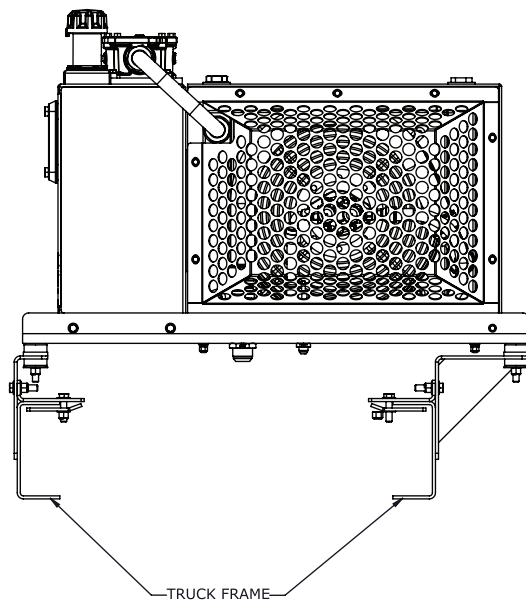

QUICK MOUNT OPTION #2
Reverse the quick mount brackets to attach to the top of thicker frames. Does not require any drilling or modification to the truck frame.

