

## UK12-70-HYD-FRM-PC

1156082

The Ultra-Kool is a compact hydraulic reservoir, filter and cooler system. The frame isolation mounts make this perfect for severe applications.

Typical applications include:

Fertilizer Tenders  
Petroleum Trucks  
Seed Conveyors  
Feed Body Trailers  
Water Tanks



## FEATURES

- ✓ High Flow Integral 10 Micron Filter with 25 PSI Bypass
- ✓ 40 Micron Filler-Breather
- ✓ Sight Level-Temperature Gauge
- ✓ Filter Element Condition Indicator Gauge
- ✓ 80 GPM Oil Cooler with Hydraulic Fan
- ✓ 12 Gallon Reservoir
- ✓ Powder Coated Steel Construction
- ✓ Cab Mounting Brackets Available
- ✓ 2" NPT Suction Ports (Qty 2)
- ✓ #20 ORB Return Port
- ✓ 2" Male NPT 100 Mesh Suction Strainer with 3 PSI Bypass
- ✓ 1-1/4" NPT Port for Available Temp/Level Sensor (Sensor Not Included)

## PRODUCT & TECHNICAL SPECIFICATIONS

The **Inlet Temperature Difference** is the difference between the inlet oil temperature and the inlet air temperature in Fahrenheit. The smaller the difference is, the less ability the heat exchanger has to cool the oil.

**BOL Models with Standard P-BAR Core**

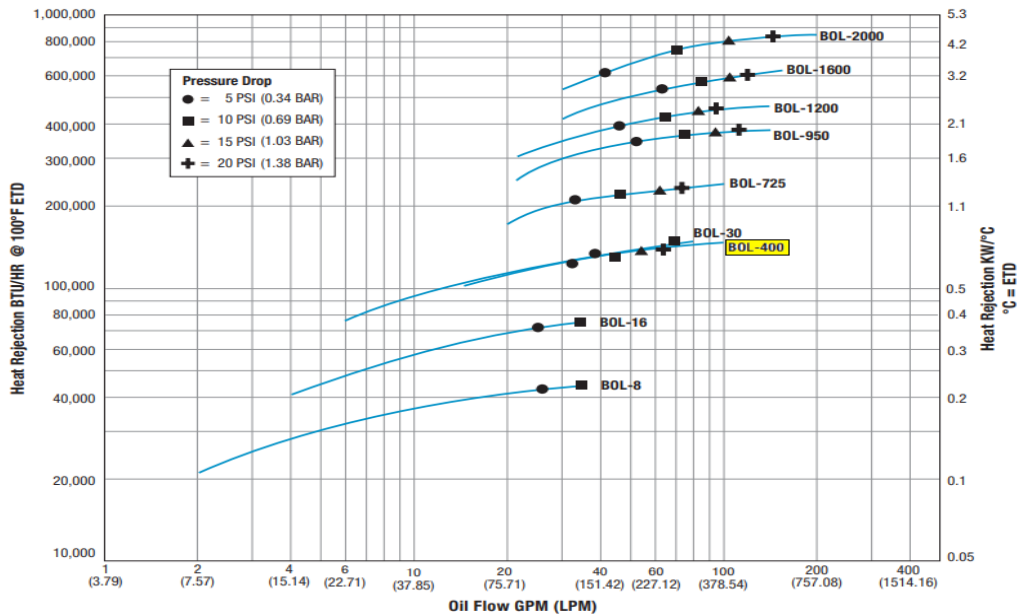

**Model Number:**

UK12-70 - 12 Gallon Reservoir - Hydraulic Fan  
70 Gallons per minute of intermittent use  
Intermittent use is described as 20 minute intervals.

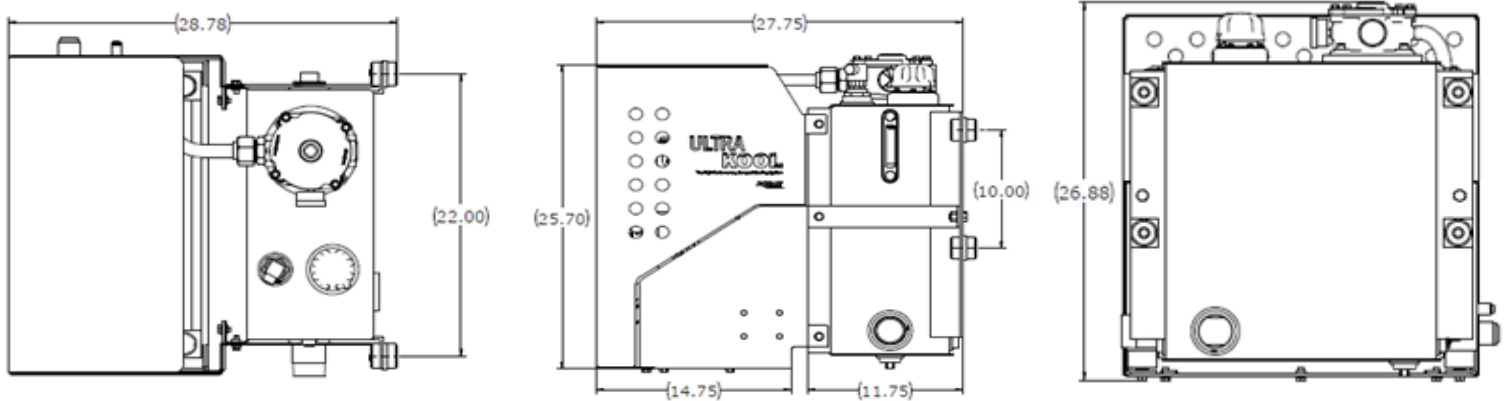

## Model Code Breakdown

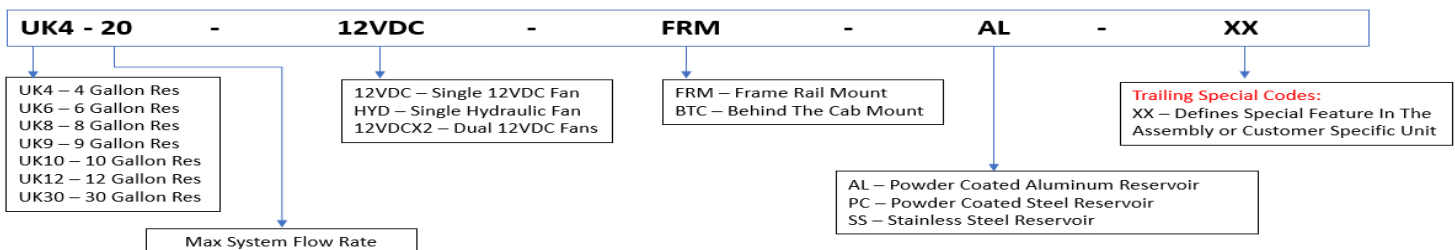

1212238