

UK12-70-HYD-BTC-SS

The Ultra-Kool is a compact hydraulic reservoir, filter and cooler system. The frame isolation mounts make this perfect for severe applications.

Typical applications include:

Fertilizer Tenders
Petroleum Trucks
Seed Conveyors
Feed Body Trailers
Water Tanks



FEATURES

- ✓ High Flow Integral 10 Micron Filter with 25 PSI Bypass
- ✓ 10 Micron Filler-Breather
- ✓ Sight Level-Temperature Gauge
- ✓ Filter Element Condition Indicator Gauge
- ✓ 80 GPM Oil Cooler with Hydraulic Fan
- ✓ Stainless Steel Construction
- ✓ 2" NPT Suction Ports (Qty 2)
- ✓ #20 ORB Return Port
- ✓ 12 Gallon Reservoir

PRODUCT & TECHNICAL SPECIFICATIONS

The **Inlet Temperature Difference** is the difference between the inlet oil temperature and the inlet air temperature in Fahrenheit. The smaller the difference is, the less ability the heat exchanger has to cool the oil.

BOL Models with Standard P-BAR Core

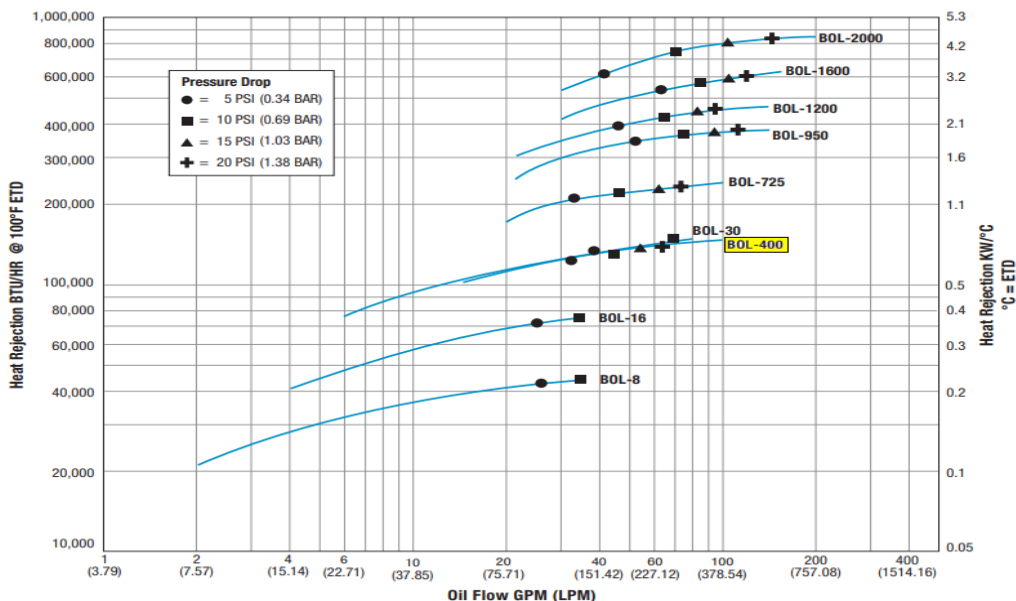

Model Number:

UK12-70 - 12 Gallon Reservoir - Hydraulic Fan
70 Gallons per minute of intermittent use
Intermittent use is described as 20 minute intervals.

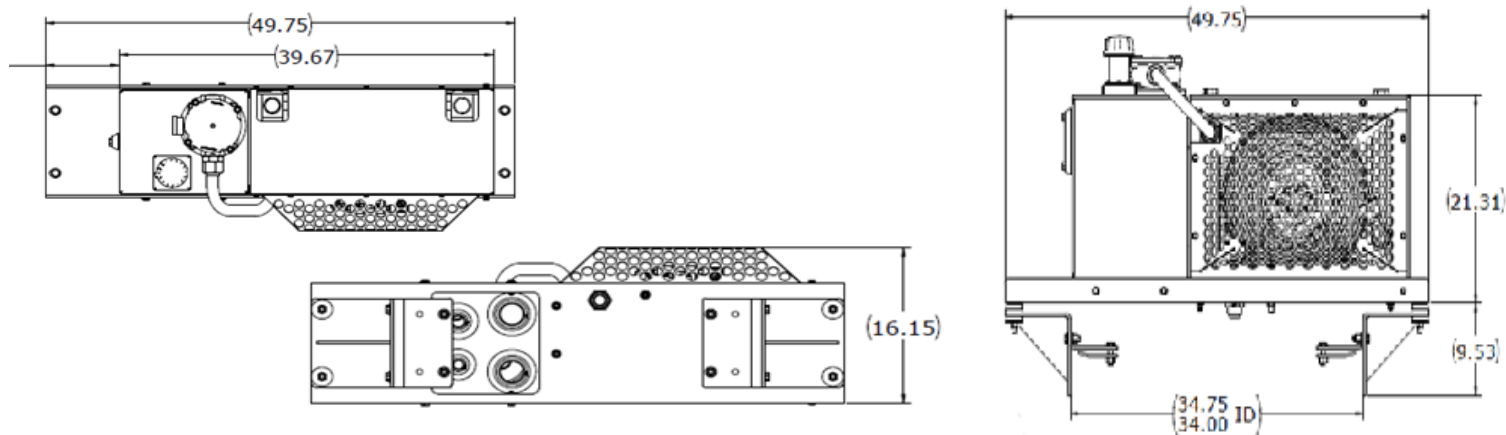

Model Code Breakdown

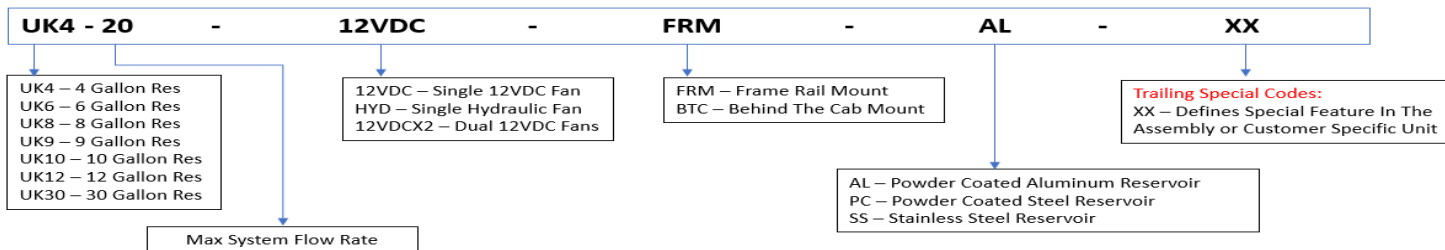

1212241