

UK12-70-12VDC-FRM-SS

1190252

The Ultra-Kool is a compact hydraulic reservoir, filter and cooler system. The frame isolation mounts make this perfect for severe applications.

Typical applications include:

Fertilizer Tenders
Petroleum Trucks
Seed Conveyors
Feed Body Trailers
Water Tanks



FEATURES

- ✓ High Flow Integral 10 Micron Filter with 25 PSI Bypass
- ✓ 10 Micron Filler-Breather
- ✓ Sight Level-Temperature Gauge
- ✓ Filter Element Condition Indicator Gauge
- ✓ 12 Gallon Reservoir
- ✓ #20 ORB Return Port
- ✓ Powder Coated Steel Construction
- ✓ Cab Mounting Brackets Available
- ✓ 2" NPT Suction Ports (Qty 2)
- ✓ 2" Male NPT 100 Mesh Suction Strainer with 3 PSI Bypass
- ✓ 1-1/4" NPT Port for Available Temp/Level Sensor (Sensor Not Included)

PRODUCT & TECHNICAL SPECIFICATIONS

The **Inlet Temperature Difference** is the difference between the inlet oil temperature and the inlet air temperature in Fahrenheit. The smaller the difference is, the less ability the heat exchanger has to cool the oil.

MA Models - DC Fan Assemblies

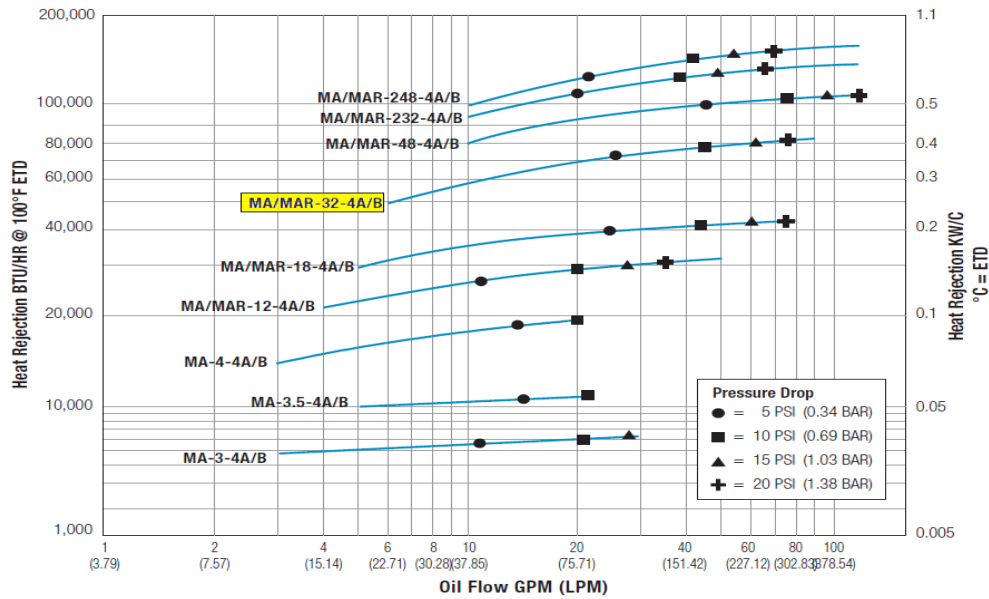

Model Number:

UK12-70 - 12 Gallon Reservoir - 12VDC Fan
70 Gallons per minute of intermittent use
Intermittent use is described as 20 minute intervals.

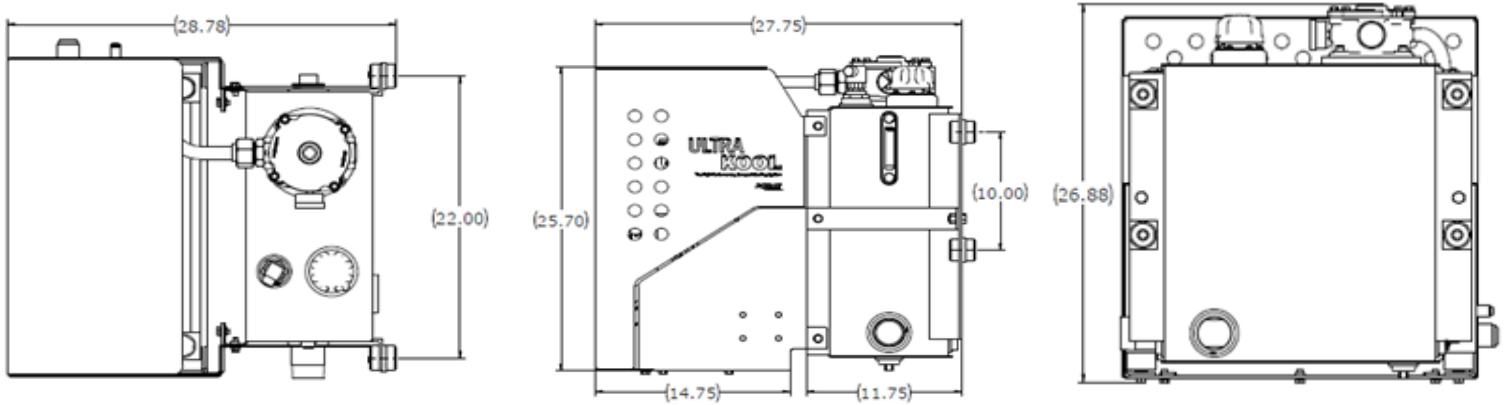

Model Code Breakdown

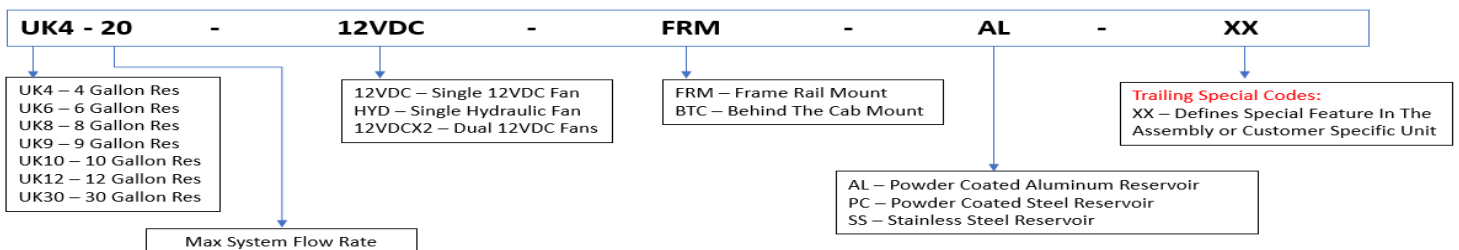

1212237