

PERFORMANCE CURVES

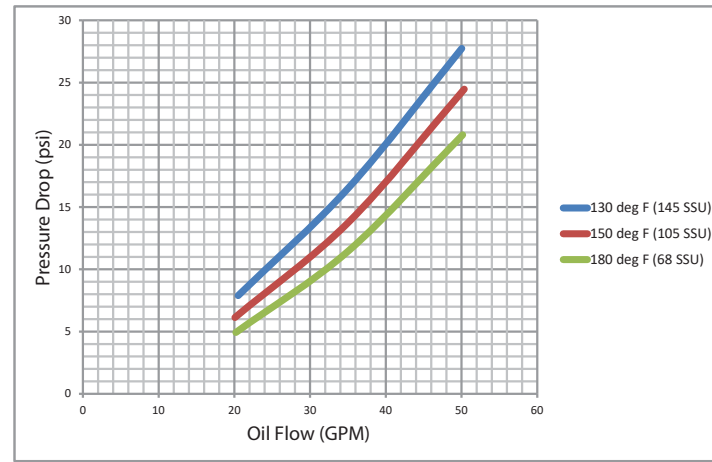
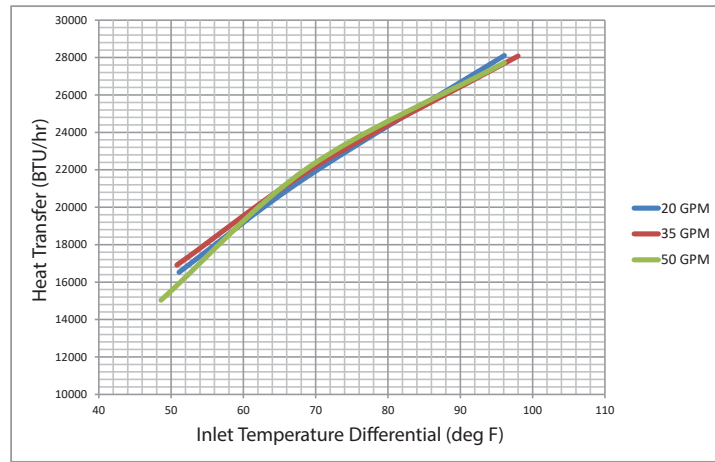

PACKAGE DIMENSIONS

Each UK8-50-SS-12VDC comes standard with a 10 micron filler breather, 10 micron filter with a 25 psi bypass, power harness and quick mount bracket set.

Port Sizes

- Suction 2" NPT
- Relief Valve Return 1" NPT
- Drain 3/4" NPT
- Cooler Return SAE -20

Weight

Dry Weight 118 lbs

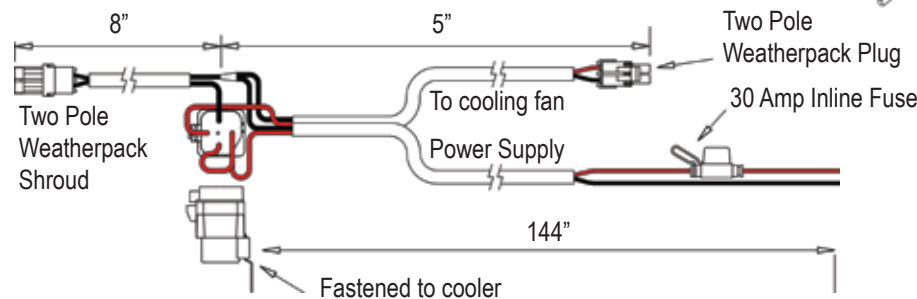
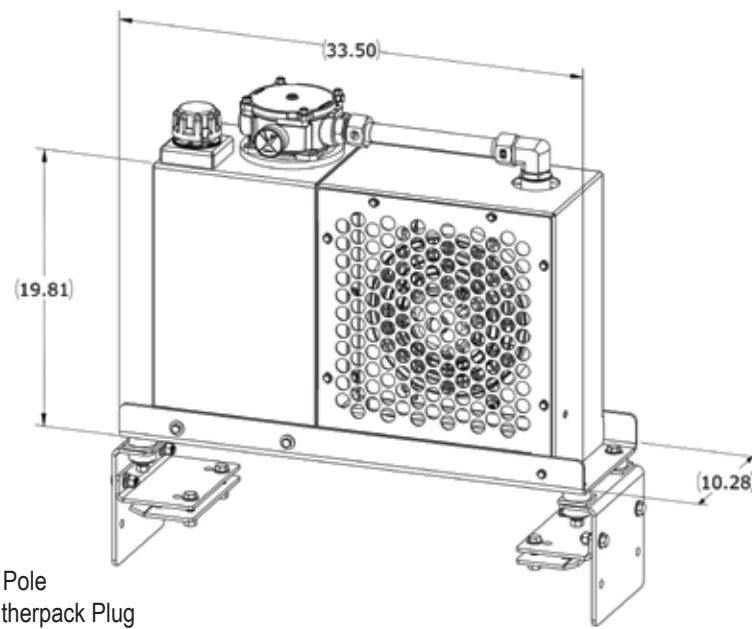

1-888-99-FORCE

501 East Cliff Road Burnsville, Minnesota 55337 www.forceamerica.com

Service Centers and Sales

Bismarck, ND	800-624-7568	Denver, CO	888-833-7711	Minneapolis, MN	800-328-2732
Charlotte, NC	800-788-8598	Fort Dodge, IA	800-362-2994	Philadelphia, PA	800-492-6621
Chicago, IL	800-433-5765	Kansas City, MO	800-383-4724	Salt Lake City, UT	877-230-0505
Columbus, OH	888-449-0356	Memphis, TN	888-845-5876		
Dallas, TX	800-893-7225	Milwaukee, WI	800-722-5844		
Atlanta, GA (Atlanta Powertrain™)			888-293-2325		www.atlantapowertrain.com
Seattle, WA (Mobile Equipment Systems™)			800-354-9028		www.mobileequip.com

FEATURES

The Ultra-Kool is a compact hydraulic reservoir, filter and cooler system. The stainless steel construction, EnduraGuard™ filter housing and filler breather, and frame isolation mounts make this perfect for severe applications.

High Flow Capacity

- 50 GPM rated cooler and filter circuit
- SAE -20 return ports for low pressure drop

Multiple Mounting Options

- System includes quick mount brackets, no drilling required
- Option to mount direct to truck frame

Space Saving Design

- Behind the cab mounting requires less than 12" of space

Multiple Fan Switching Options

- Power harness and relay come standard
- Optional harness for air or electric shift PTOs
- Temperature switch option for fan activation at 120 degrees F oil temperature
- Override switch option for additional fan control



Configure your own system by selecting model codes from each option below.

MONUING OPTIUNS

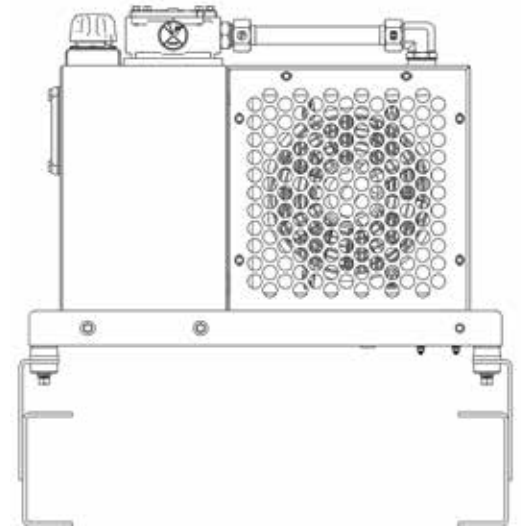

DIRECT MOUNT

Directly mount the provided brackets to the truck frame and discard the quick mount brackets.

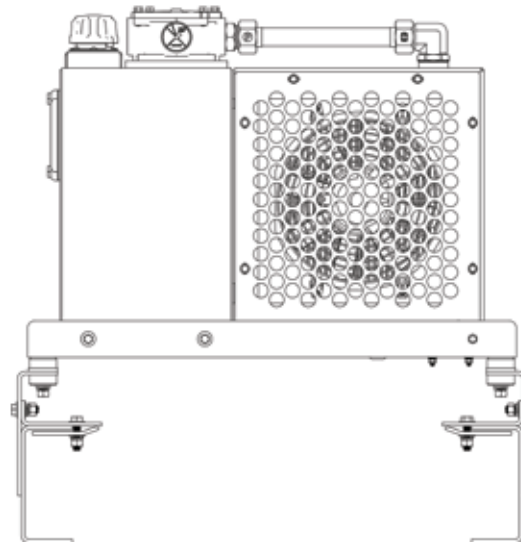

QUICK MOUNT OPTION #1

Use quick mount brackets to attach to the top of the truck frame rail. Does not require any drilling or modification to the truck frame.

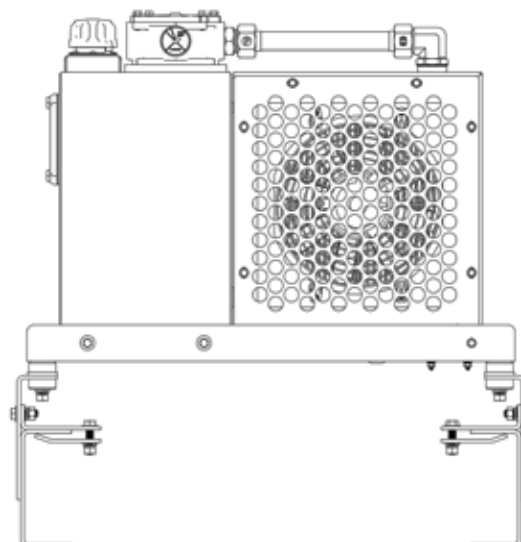

QUICK MOUNT OPTION #2

Reverse the quick mount brackets to attach to the top of thicker frames. Does not require any drilling or modification to the truck frame.

UK8-50-12VDC-SS



BASE MODEL

SWITCHING KIT

OVERRIDE KIT

Switching Kits	
Code	Description
ASW	Air Shift PTO Switch Kit
<p>The air switch option uses a heavy duty air pressure switch connected to the PTO air circuit to turn the fan on. This kit includes the air switch and mating connector to the main power harness.</p>	
GSW	Electric Shift PTO Switch Kit
<p>The ground switch option is used for electric shift PTOs. This kit includes the harness needed to connect the UK8-50 main power harness to the PTO ground switch.</p>	
TSW	Temperature Switch Kit
<p>The temperature switch option includes a 1/4" NPT thermal switch with a 120 degree F switching point. Use this option independent of an air or ground switch to activate the 12 VDC fan at 120 degrees F.</p>	

Override Kit	
Code	Description
O	Fan Override Switch Kit
<p>The Override Kit includes a toggle switch which allows fan activation. Use this option in conjunction with one of the Switching Kits (ASW, GSW, TSW).</p>	