

FEATURES

The Ultra-Kool is a compact hydraulic reservoir, filter and cooler system. The frame isolation mounts make this perfect for severe applications.

Typical Applications include:

Fertilizer Tenders
Petroleum Trucks
Seed Conveyors
Feed Body Trailers
Water Tanks

The Ultra-Kool includes the following items:

- 40 GPM oil cooler with 12vdc electric fan
- 6 gallon reservoir
- High flow integral 10 micron filter with 25 PSI bypass
- 40 Micron filler-breather
- Sight level-temperature gauge
- Filter element condition indicator gauge
- 2" NPT suction ports (2)
- #16 ORB Return Port
- 1 1/4" NPT port for available level/temp sensor (not included)
- 2" Male NPT 100 mesh suction strainer with 3 psi bypass rated for 26 GPM at 5 ft./second
- Powder coated steel construction
- Weight: 95lbs
- Cab mounting brackets available



PERFORMANCE CURVES

The Inlet Temperature Difference is the difference between the inlet oil temperature and the inlet air temperature in F. The smaller this difference is, the less ability the heat exchanger has to cool the oil.

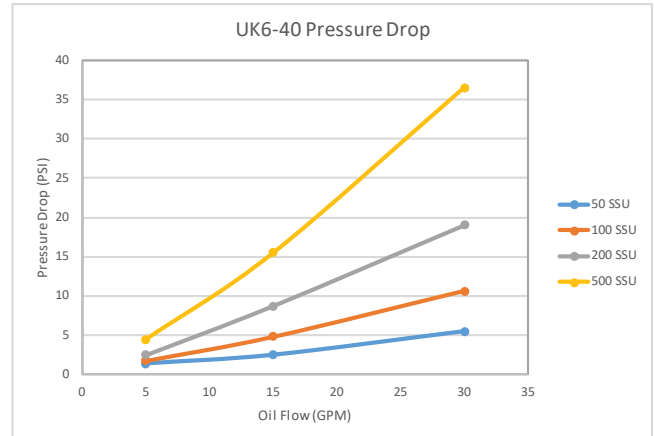
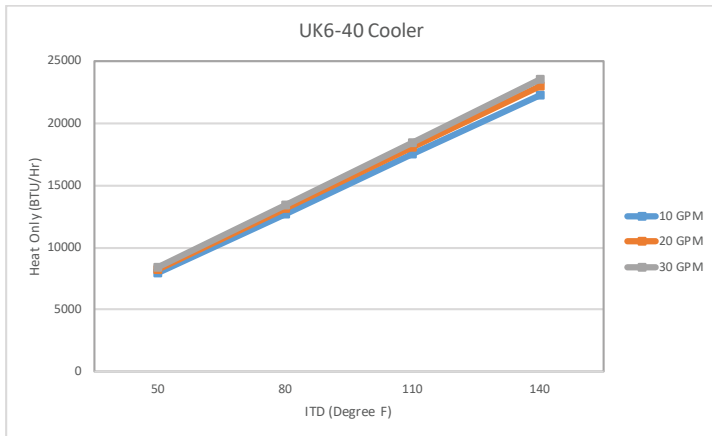

PACKAGE DIMENSIONS

Model Numbers

UK6-40 6 Gallon Reservoir 12VDC Fan

40 Gallons per minute for intermittent use.

Intermittent use is defined as 20 minute intervals.

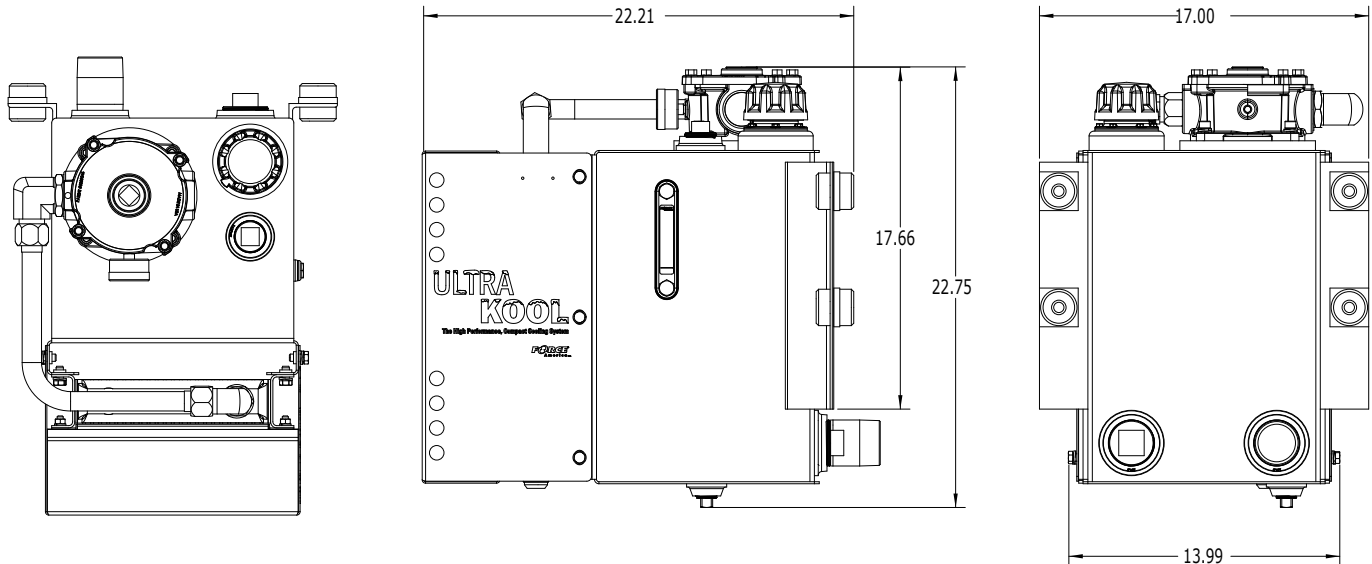

1-888-99-FORCE

501 East Cliff Road Burnsville, Minnesota 55337 www.forceamerica.com

Sales and Service Centers

Bismarck, ND	800-624-7568	Denver, CO	888-833-7711	Minneapolis, MN	800-328-2732
Charlotte, NC	800-788-8598	Fort Dodge, IA	800-362-2994	Philadelphia, PA	800-492-6621
Chicago, IL	800-433-5765	Kansas City, MO	800-383-4724	Salt Lake City, UT	877-230-0505
Columbus, OH	888-449-0356	Memphis, TN	888-845-5876		
Dallas, TX	800-893-7225	Milwaukee, WI	800-722-5844		