

REVISIONS				
REV	ECO NUMBER	DESCRIPTION	DATE	BY
A	EDO-002030	INITIAL RELEASE	12/15/2015	JNP

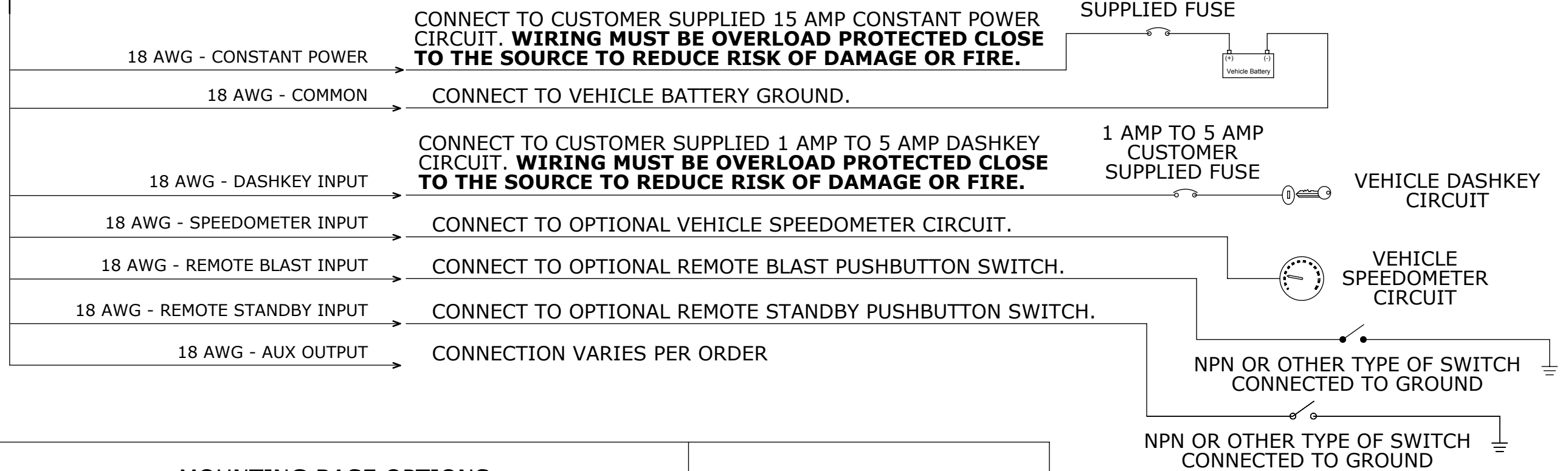

BACK VIEW
(CONNECTIONS AND MOUNTING)

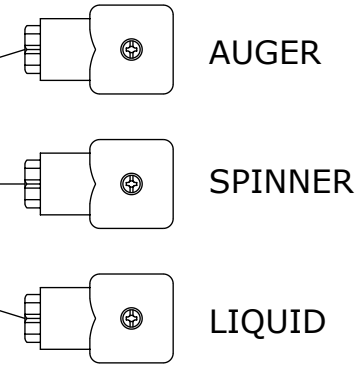
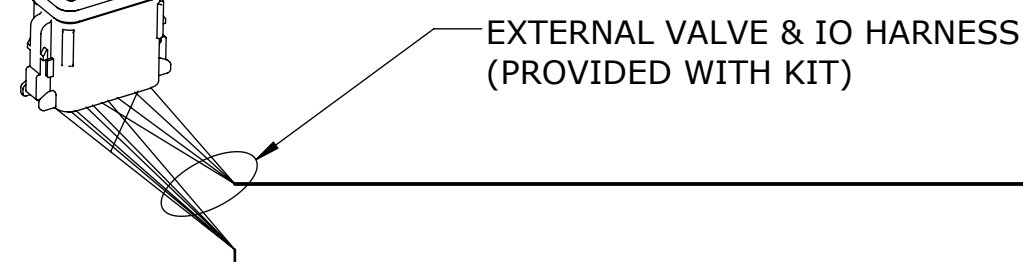
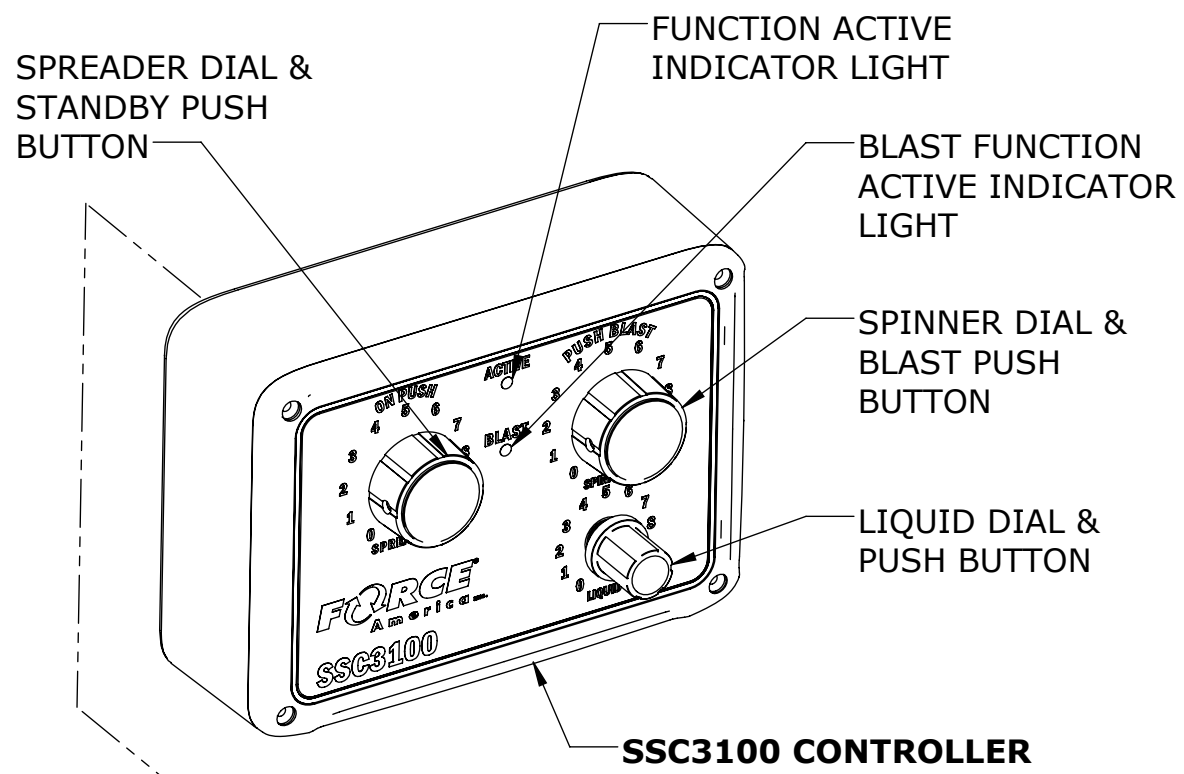
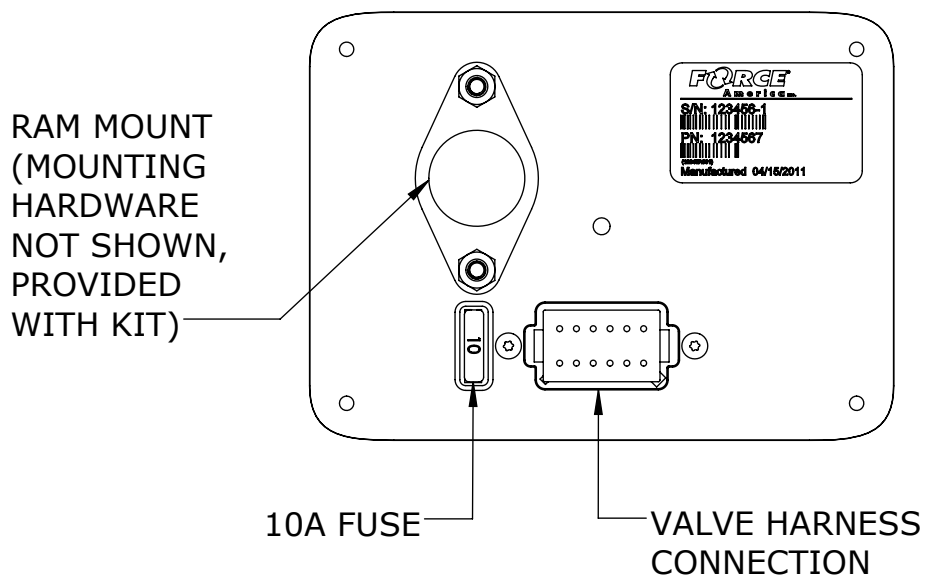

MOUNTING BASE OPTIONS
(NOT TO SCALE)

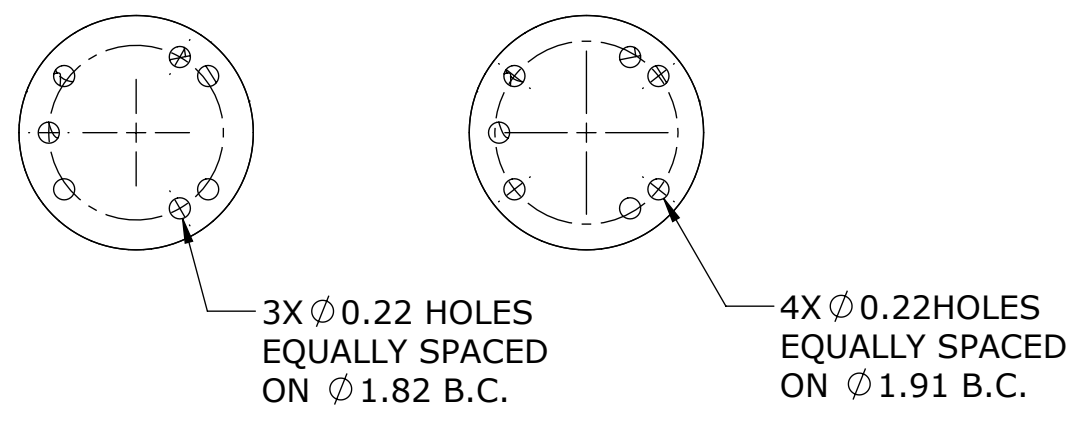

OPTIONAL COMPONENTS
(ORDERED SEPARATELY)

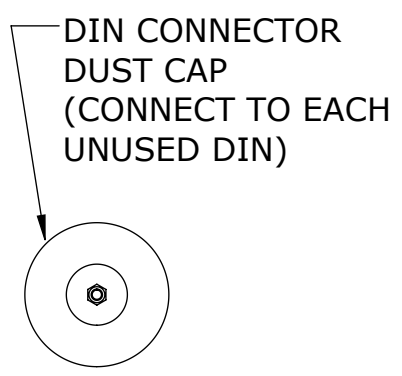

THIS DRAWING IS THE PROPERTY OF FORCE AMERICA, INC. IT CONTAINS PROPRIETARY INFORMATION AND IS TRANSMITTED AS A CONFIDENTIAL DISCLOSURE. IT MAY NOT BE COPIED OR ITS CONTENTS REVEALED TO OTHERS WITHOUT WRITTEN CONSENT OF FORCE AMERICA, INC.

MATERIAL NA		DRAWN BY JNP
TOLERANCE, INCHES UNLESS OTHERWISE SPECIFIED. DEC. XX ±.010 DEC. XXX ±.005 ANGULAR: MACH ± 2°		DATE 12/9/2015
THIRD ANGLE PROJECTION	TITLE INSTALLATION, CONTROLLER, SPREADER, SSC3100	APP'VD BY MJH
	SIZE DWG. NO. C 4415	DATE 12/15/2015
	SCALE 1:2 DO NOT SCALE DRAWING	REV A
		SHEET 1 OF 1