

| REVISIONS | | | | |
|-----------|------------|-----------------|-----------|-----|
| REV | ECO NUMBER | DESCRIPTION | DATE | BY |
| A | 005313 | INITIAL RELEASE | 6/14/2018 | DGH |

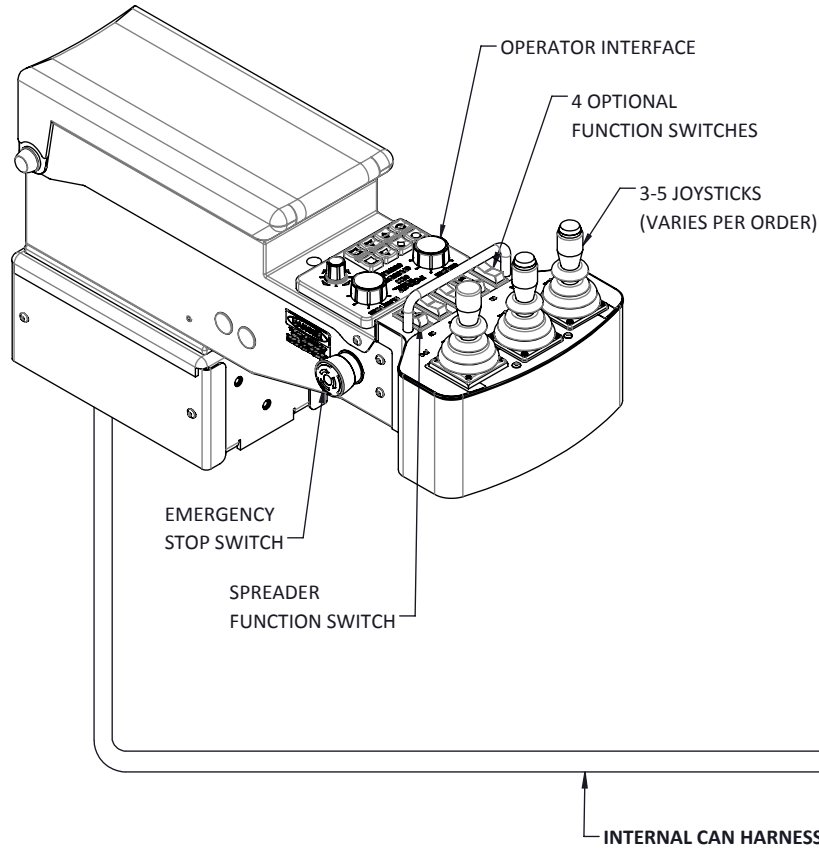

6100 HUB
SEE DOCUMENT # 4511 FOR
MODULE INSTALLATION INSTRUCTIONS.

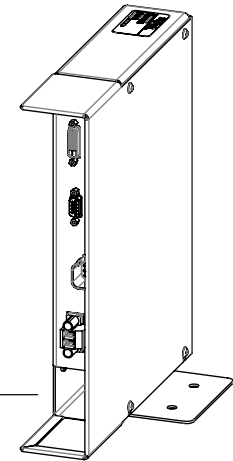
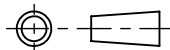

| | | | | |
|---|---|----------------------|-----------|--------------|
| THIS DRAWING IS THE PROPERTY OF FORCE AMERICA, INC. IT CONTAINS PROPRIETARY INFORMATION AND IS TRANSMITTED AS A CONFIDENTIAL DISCLOSURE. IT MAY NOT BE COPIED OR ITS CONTENTS REVEALED TO OTHERS WITHOUT WRITTEN CONSENT OF FORCE AMERICA, INC. | | | | |
| MATERIAL |  | | DRAWN BY | DGH |
| TOLERANCE - INCHES UNLESS OTHERWISE SPECIFIED. DEC. XX ±.010 DEC. XXX ±.005 ANGULAR: MACH ± 2° | | | DATE | 6/13/2018 |
| THIRD ANGLE PROJECTION | SIZE | DWG. NO. | APPV'D BY | DATE |
|  | A | 4508 | | |
| TITLE | | | REV | |
| INSTALLATION, ASM, ARM, ULTRA, 6100, GEN 5 | | | A | |
| SCALE 1:6 | | DO NOT SCALE DRAWING | | SHEET 1 OF 1 |