

REVISIONS				
REV	ECO NUMBER	DESCRIPTION	DATE	BY
A	001498	INITIAL RELEASE	8/25/2015	JNP

****BOTTOM VIEW****

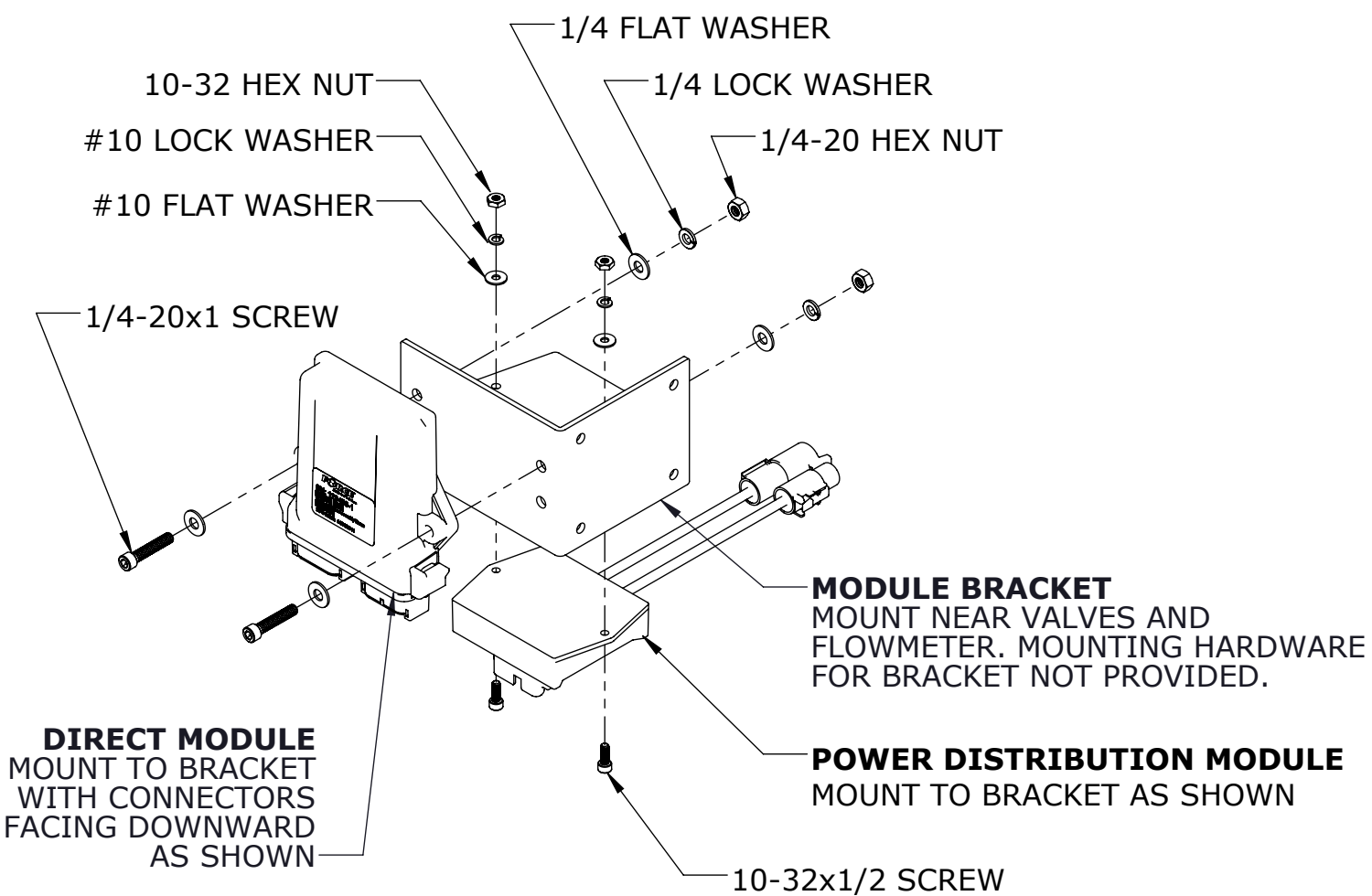

BRACKET MOUNTING PATTERN
FOR REFERENCE USE

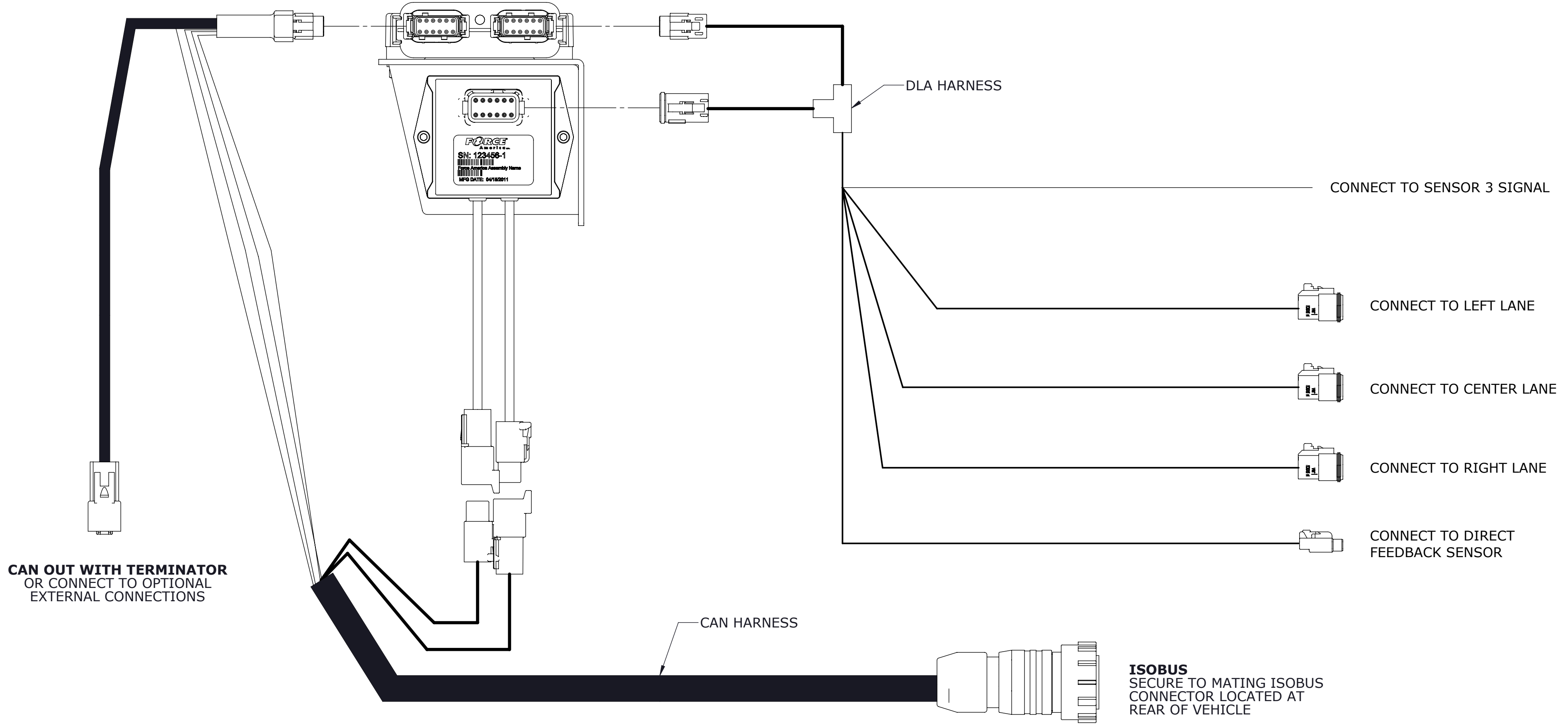
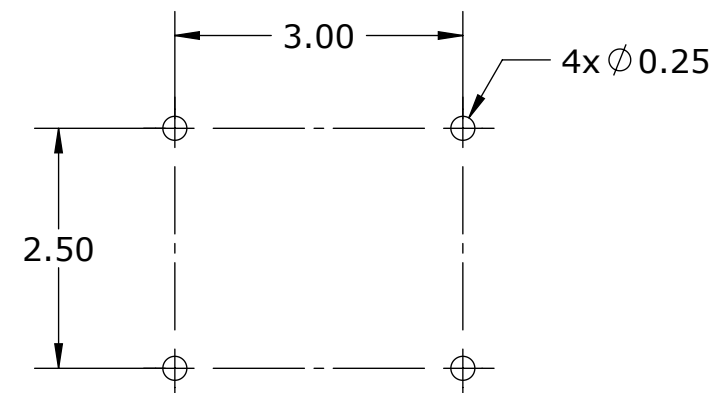

THIS DRAWING IS THE PROPERTY OF FORCE AMERICA, INC. IT CONTAINS PROPRIETARY INFORMATION AND IS TRANSMITTED AS A CONFIDENTIAL DISCLOSURE. IT MAY NOT BE COPIED OR ITS CONTENTS REVEALED TO OTHERS WITHOUT WRITTEN CONSENT OF FORCE AMERICA, INC.

MATERIAL		DRAWN BY JNP	
TOLERANCE, INCHES UNLESS OTHERWISE SPECIFIED.		DATE 08/21/2015	
DEC. XX ±.010	DEC. XXX ±.005	APP'VD BY CM	
ANGULAR: MACH ± 2°		DATE 08/25/2015	
TITLE			
INSTALLATION, KIT, ISOBUS, DLA, 6100			
THIRD ANGLE PROJECTION	SIZE C	DWG. NO. 4404	REV A
SCALE 1:2		DO NOT SCALE DRAWING	
SHEET 1 OF 1			